

SCANCLIMBER® SC300K / SC400K

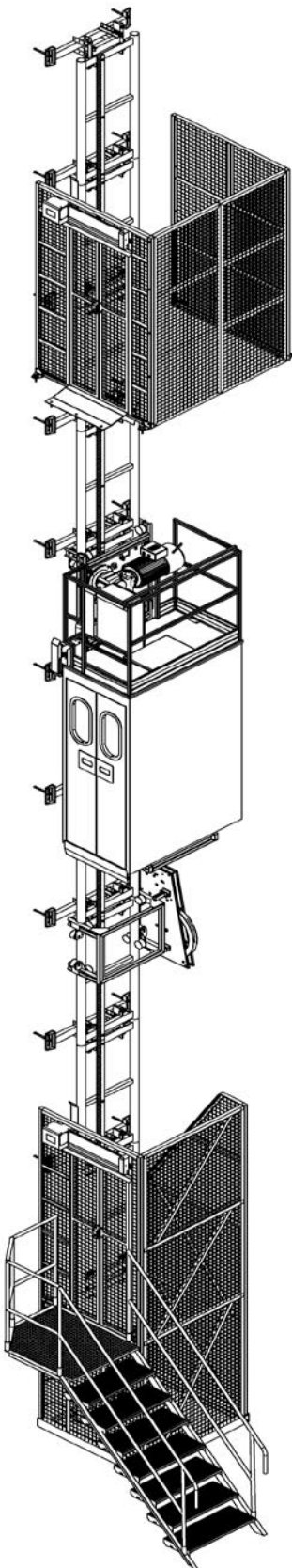

Industrial hoist

Applications in different industries:

- Cranes
- Chimneys
- Bleach towers



Technical data	SC300K	SC400K
Payload	300 kg 3 persons	400 kg 4 persons
Speed	36 m/min	36 m/min
Lifting height	200 m	200 m
Cage dimensions		
• internal w x l	775 x 1043 mm	780 x 1270 mm
• door opening	720 x 2000 mm	780 x 2000 mm
Lifting unit		
• type	top drive	top drive
• motor	1 x 7,5 kW	1 x 9,2 kW
Power supply		
• voltage	400/50 VAC/Hz	400/50 VAC/Hz
• current	32 A	40 A
Safety device	UC3.0 A	UC3.0 A
Mast tubular steel with integrated rack		
• section length	1508 mm	1508 mm

V08_04.07

OY SCANINTER NOKIA LTD

Turkkirata 26

FI-33960 PIRKKALA, FINLAND

Tel. +358 10 680 7000 Fax +358 10 680 7033

SCANCLIMBER®

www.scanclimber.com